

# baridi

---

## Horizontal Traditional 2 Column Radiator

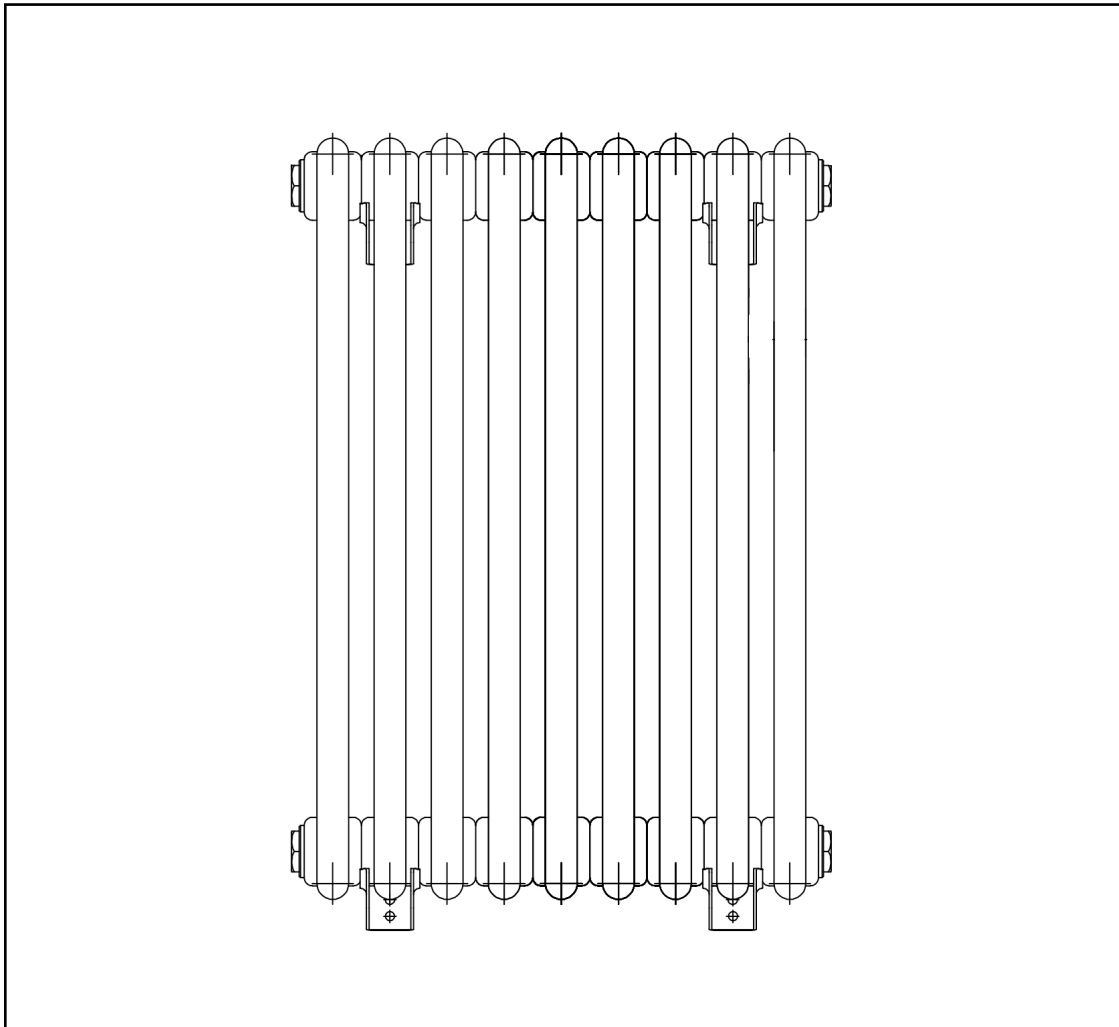

**Models: DH356 DH357 DH358 DH359 DH360 DH361 DH362 DH363  
DH364 DH365 DH366 DH367 DH368 DH369 DH370**

Thank you for purchasing a Dellonda product. Manufactured to a high standard, this product will, if used according to these instructions, and properly maintained, give you years of trouble free performance.

## IMPORTANT INFORMATION

Please read these instructions carefully. Note the safe operational requirements, warnings & cautions. Use the product correctly and with care for the purpose for which it is intended. Failure to do so may cause damage and/or personal injury and will invalidate the warranty. Keep these instructions safe for future use.



Refer to instructions



Indoor use only



Wear eye protection



Wear protective gloves



Wear safety footwear

### • SPECIFICATION

Model No:	DH356	DH357	DH358	DH359	DH360
Dimensions (W x D x H):	427 x 70 x 600mm	607 x 70 x 600mm	832 x 70 x 600mm	1012 x 70 x 600mm	1147mm x 70mm x 600mm
Fitting:	Wall Mounted	Wall Mounted	Wall Mounted	Wall Mounted	Wall Mounted
Inlet Connection:	1/2" BSP	1/2" BSP	1/2" BSP	1/2" BSP	1/2" BSP
Installation Type:	Hot Water/Central Heating	Hot Water/Central Heating	Hot Water/Central Heating	Hot Water/Central Heating	Hot Water/Central Heating
Material:	Steel	Steel	Steel	Steel	Steel
Nett Weight:	9.3kg	15.4kg	22.1kg	27.7kg	30.4kg
No. of Columns:	18 in total (9 Doubled)	26 in total (13 Doubled)	36 in total (18 Doubled)	44 in total (22 Doubled)	50 in total (25 Doubled)
Output BTU:	1433	2072	2870	3505	3986
Output Watts:	420	607	841	1027	1168
Pipe Centres:	515mm	695mm	920mm	1100mm	1235mm
Projection from Wall:	98mm	98mm	98mm	98mm	98mm
Wall to Pipe Centres:	63mm	63mm	63mm	63mm	63mm
Colour:	Anthracite	Anthracite	Anthracite	Anthracite	Anthracite
Distance from Wall to Inlet/Outlet centre:	63mm	63mm	63mm	63mm	63mm
Water content:	5.5L	7.9L	11L	13.4L	15L
Rated Thermal output (W):	223	322	446	545	619
Thermal Output in different operating conditions:	1,4888Km	2,1505Km	2,9776Km	3,6393Km	4,1356Km
Type:	Horizontal	Horizontal	Horizontal	Horizontal	Horizontal
Water Pressure:	12bar	12bar	12bar	12bar	12bar
Floor to Centre of Pipe Connectors:	N/A	N/A	N/A	N/A	N/A

Model No:	DH361	DH362	DH363	DH364	DH365
Dimensions (W x D x H):	427 x 70 x 600mm	607 x 70 x 600mm	832 x 70 x 600mm	1012 x 70 x 600mm	1147mm x 70mm x 600mm
Fitting:	Wall Mounted	Wall Mounted	Wall Mounted	Wall Mounted	Wall Mounted
Inlet Connection:	1/2" BSP	1/2" BSP	1/2" BSP	1/2" BSP	1/2" BSP
Installation Type:	Hot Water/Central Heating	Hot Water/Central Heating	Hot Water/Central Heating	Hot Water/Central Heating	Hot Water/Central Heating
Material:	Steel	Steel	Steel	Steel	Steel
Nett Weight:	9.3kg	15.4kg	22.1kg	27.7kg	30.4kg
No. of Columns:	18 in total (9 Doubled)	26 in total (13 Doubled)	36 in total (18 Doubled)	44 in total (22 Doubled)	50 in total (25 Doubled)
Output BTU:	1433	2072	2870	3505	3986
Output Watts:	420	607	841	1027	1168
Pipe Centres:	515mm	695mm	920mm	1100mm	1235mm
Projection from Wall:	98mm	98mm	98mm	98mm	98mm
Wall to Pipe Centres:	63mm	63mm	63mm	63mm	63mm
Colour:	Black	Black	Black	Black	Black

Model No:	DH361	DH362	DH363	DH364	DH365
Distance from Wall to Inlet/Outlet centre:	63mm	63mm	63mm	63mm	63mm
Water content:	5.5L	7.9L	11L	13.4L	15L
Rated Thermal Output (W):	223	322	446	545	619
Thermal Output in different operating conditions:	1,4888Km	2,1505Km	2,9776Km	3,6393Km	4,1356Km
Type:	Horizontal	Horizontal	Horizontal	Horizontal	Horizontal
Water Pressure:	12bar	12bar	12bar	12bar	12bar
Floor to Centre of Pipe Connectors:	N/A	N/A	N/A	N/A	N/A

Model No:	DH366	DH367	DH368	DH369	DH370
Dimensions (W x D x H):	427 x 70 x 600mm	607 x 70 x 600mm	832 x 70 x 600mm	1012 x 70 x 600mm	1147 x 70 x 600mm
Fitting:	Wall Mounted	Wall Mounted	Wall Mounted	Wall Mounted	Wall Mounted
Inlet Connection:	1/2" BSP	1/2" BSP	1/2" BSP	1/2" BSP	1/2" BSP
Installation Type:	Hot Water/Central Heating	Hot Water/Central Heating	Hot Water/Central Heating	Hot Water/Central Heating	Hot Water/Central Heating
Material:	Steel	Steel	Steel	Steel	Steel
Nett Weight:	9.3kg	15.4kg	22.1kg	27.7kg	30.4kg
No. of Columns:	18 in total (9 Doubled)	26 in total (13 Doubled)	36 in total (18 Doubled)	44 in total (22 Doubled)	50 in total (25 Doubled)
Output BTU:	1433	2072	2870	3505	3986
Output Watts:	420	607	841	1027	1168
Pipe Centres:	515mm	695mm	920mm	1100mm	1235mm
Projection from Wall:	98mm	98mm	98mm	98mm	98mm
Wall to Pipe Centres:	63mm	63mm	63mm	63mm	63mm
Colour:	White	White	White	White	White
Distance from Wall to Inlet/Outlet centre:	63mm	63mm	63mm	63mm	63mm
Water content:	5.5L	7.9L	11L	13.4L	15L
Rated Thermal Output (W):	223	322	446	545	619
Thermal Output in different operating conditions:	1,4888Km	2,1505Km	2,9776Km	3,6393Km	4,1356Km
Type:	Horizontal	Horizontal	Horizontal	Horizontal	Horizontal
Water Pressure:	12bar	12bar	12bar	12bar	12bar
Floor to Centre of Pipe Connectors:	N/A	N/A	N/A	N/A	N/A

#### • GENERAL SAFETY

- All installation work must be carried out by a qualified and competent professional in accordance with local building and plumbing regulations.
- Always switch off and allow the heating system to cool fully before beginning any installation, maintenance, or adjustment.
- Check the wall structure is suitable to support the radiator's weight when filled with water.
- Before drilling, ensure there are no hidden pipes, wires, or structural elements in the wall.
- Use appropriate personal protective equipment (PPE), including gloves and eye protection, during installation.
- **DO NOT** modify, drill, or alter the radiator or its fittings in any way.
- Keep combustible or flammable materials away from the radiator at all times.
- Inspect the finish on the product for signs of damage before installation.
- After installation, all connections must be checked for leaks prior to operating the heating system.
- Take care around hot surfaces. Supervise children and vulnerable individuals near the radiator to prevent accidental burns.
- **DO NOT** hang wet clothes directly on the radiator without using a suitable drying rack.
- Keep flammable materials away from the radiator surface.
- This product can only be used at **PN 1MPa** (10g/cm<sup>2</sup>, 10 Bar). It should only be filled with water, and at a temperature below 100 °C (212°F).
- If the surface temperature exceeds 48 °C (120 °F), a visible warning sign must be displayed near the product to alert users to the potential burn or scalding hazard. This precaution helps prevent accidents and ensures safe operation for all users.
- This product is only suitable for use with indirect or sealed central heating systems, including combination (combi) boilers. It must not be connected to open vented or direct heating systems.
- To ensure long-lasting performance and reliability of your radiator, it is essential to flush your central heating system with a central heating cleanser before installation to remove any sludge or debris, and then protect the system with a central heating inhibitor to prevent corrosion and scale build-up. These two simple steps will greatly improve the efficiency and lifespan of your heating system and radiator. Failure to complete them may lead to pinhole leaks and will invalidate the radiator's guarantee.

**• CONTENTS**

- Your radiator is supplied with four brackets and fixings to securely mount it to the wall (fig.1).

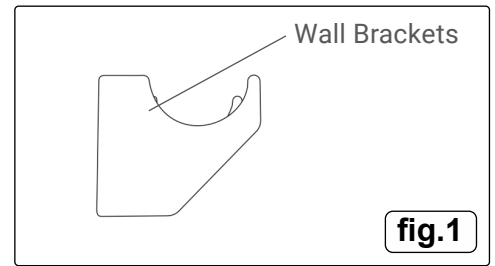

**• INSTALLATION**

**1. Tools Required (fig.2)**

- Adjustable spanner.
- Drill & appropriate masonry bits.
- Screwdriver.
- PTFE tape.
- Tape measure.
- Hammer.
- Spirit level.
- Radiator key (not illustrated).

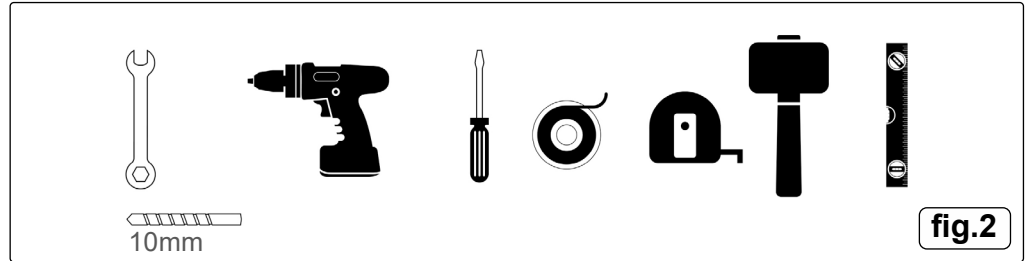

**2. Radiator Valve Installation Instructions (fig.3)**

Please ensure that radiator valves are fitted according to the diagrams provided. It is essential that a bleed point remains at the top of the radiator at all times to allow for proper air removal during operation. If both flow and return connections are made to the bottom of the radiator.

**3. Pre-Installation Checks**

- Inspect the radiator for damage or paint defects before installation. Do not install a damaged product.
- Check the wall strength. This radiator must be mounted on a solid wall capable of supporting its weight when full of water.
- Ensure your heating system is turned off and fully cooled.
- Drain the system if replacing an existing radiator.

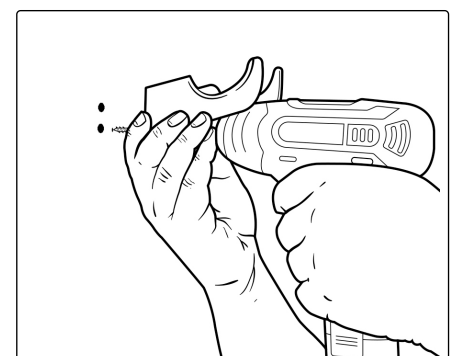
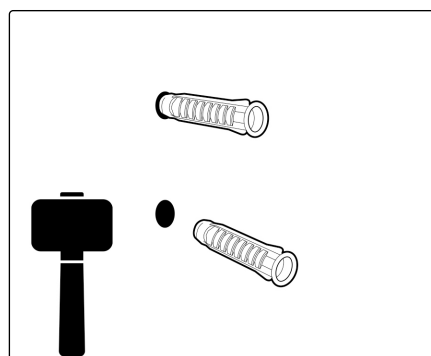
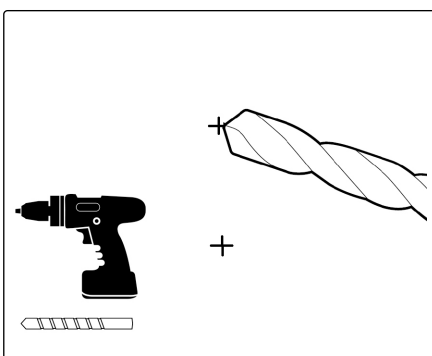
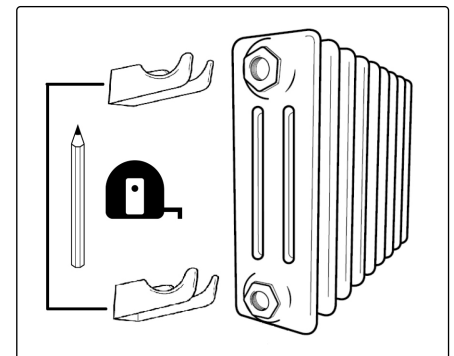
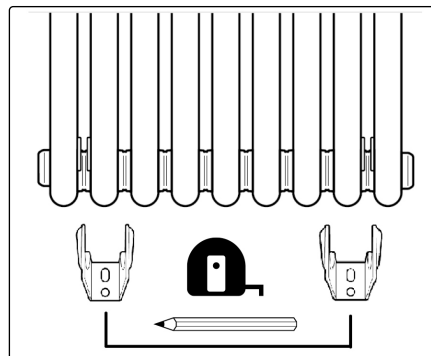
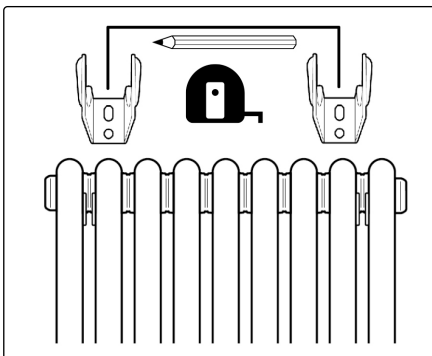
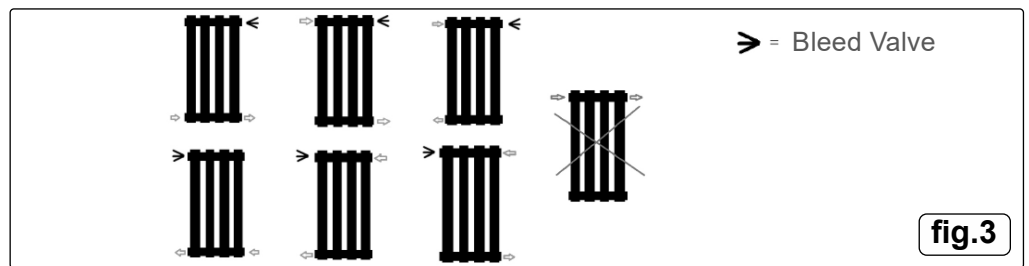

**4. Mounting the Radiator**

- Mark bracket positions:
- Use a tape measure and spirit level to mark the top and bottom bracket positions on the wall according to the radiator's fixing centres.
- Double-check measurements so the radiator sits level and at least 100 mm above the floor for airflow.
- Drill holes:
- Drill into the wall at the marked positions.
- Insert suitable wall plugs.
- Fix brackets:
- Secure the brackets using the provided hardware.
- Ensure the wall brackets are securely fixed, tight, and perfectly level using a spirit level, then carefully lift the radiator and align its mounting points with the brackets. Lower the radiator gently into place so it sits firmly and evenly on the brackets, checking that it is stable, level, and fully supported before proceeding with any plumbing or connection work.

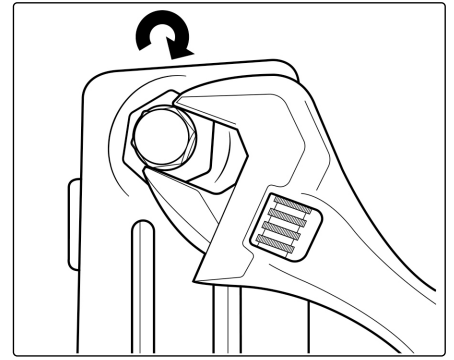
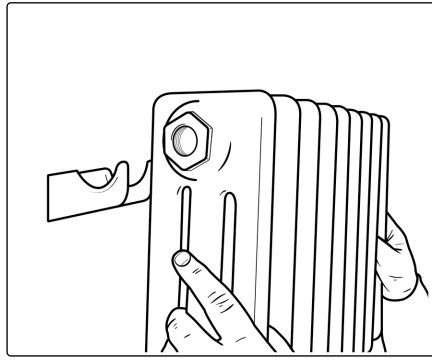
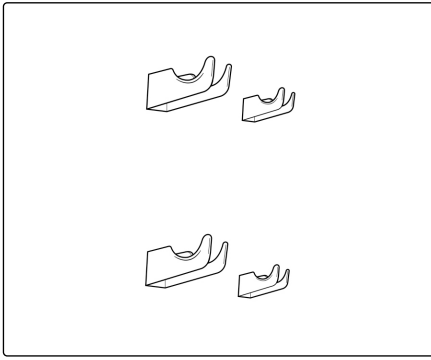

## 5. Plumbing Connection

- Wrap PTFE tape around the radiator valve tails.
- Fit radiator valves (not supplied) to the inlets at the bottom of the radiator.
- Connect the valves to your central heating pipework.
- Fit the blanking plug and bleed valve to the top opposite ends of the radiator. Tighten securely.

## 6. Filling & Bleeding

- Refill your central heating system slowly.
- Use a radiator key to bleed air from the top bleed valve until water flows steadily.
- Check for leaks at all connections and tighten if necessary.
- Once the system is full and bled, switch on the heating to check the radiator warms evenly.

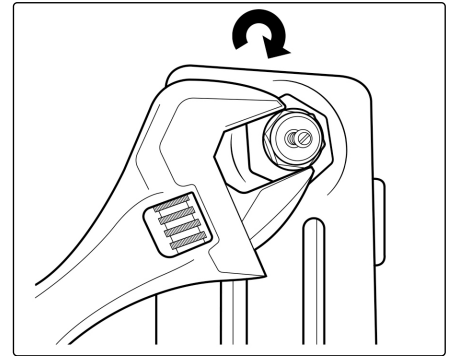

## • MAINTENANCE

- **Cleaning:** Wipe with a soft, damp cloth. Do not use abrasive cleaners or solvents.
- **Annual check:** Inspect brackets and valve joints for leaks or wear.
- **Bleeding:** If the radiator has cold spots, bleed it again to remove trapped air.
- **Repainting:** Only use heat-resistant paint suitable for radiators if required.
- **Transport:** When transporting a water-filled radiator, keep it upright at all times to prevent internal pressure on joints and fittings. Handle it carefully to avoid impacts or vibrations that could damage the panels or connections. Ensure the radiator is securely positioned and supported during transport to prevent tipping or movement. Avoid exposing it to freezing temperatures, as the water inside could expand and cause leaks or cracks. If transport over long distances or in cold conditions is necessary, it is recommended to drain the radiator beforehand to eliminate the risk of damage.
- **Storage:** A water-filled radiator should be stored in an upright position to prevent internal corrosion or damage to fittings. Ensure it is kept in a dry, frost-free environment to avoid freezing, which could cause the water inside to expand and crack the radiator. Do not store it on its side or upside down, as this can trap air and stress the joints. If long-term storage is required, it's best to drain the water completely, dry the interior as much as possible, and seal the openings to prevent dust or debris from entering.

## Environment Protection and Waste Protection and Electrical Equipment Regulations (WEEE)

Recycle unwanted packaging materials. When this product is no longer required, or has reached the end of its useful life, please dispose of it in an environmentally friendly way. Drain any fluids (if applicable) into approved containers, in accordance with local waste regulations. It is our policy to continually improve products and we reserve the right to alter data, specifications and parts without prior notice. No liability is accepted for incorrect use of this product. Guarantee is 12 months from purchase date, proof of which is required for any claim.